

**6 Pack Tub Filler**

## MAXIMUM FILLING SPEEDS

Container	Trays Per Hour
Up to 6 pack trays	±1800

**NOTE:** Filling speeds may vary as they are subject to cup design and product viscosity.

## FEATURES

- All contact parts manufactured from stainless steel and/or non-corrosive materials.
- Perspex interlocking safety doors & panels.
- SEW geared drive units with variable speed control.
- Magazine fed system with pneumatic cup-suckers for automatic dispensing.
- Automatic cup dispensing to discharge conveyor.
- Optional discharge conveyoring & accumulation table.
- Pneumatic float controlled product reservoir.
- Volume-adjustable filling pumps – Piston pumps with pneumatic actuated shut off nozzles. 6 pumps adjusted individually.
- 3 separate product reservoirs for different flavours.
- Magazine fed lid/foil application system.
- Heat sealing for foil lids.
- Individual temperature control for different elements.
- Retroflective 'No tub'-'no fill/seal' sensors.
- Control panel with:
  - Emergency stop.
  - Low air-pressure alarm.
  - Displays for heating elements.
- Integrated automatic CIP available

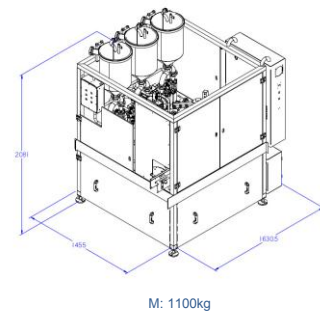

## TECHNICAL INFORMATION

ELECTRICAL POWER CONSUMPTION	5 - 8 kW (Depending on CIP setup)
VOLTAGE	380V THREE PHASE + NEUTRAL AND EARTH
MACHINE PHYSICAL SIZE	1650 x 1405 x 2000 MM
ACCUMULATION TABLE SIZE	1900 x 600 x 1000± 50mm
CRATED MASS	500 kg
AIR CONSUMPTION	300L/MIN@6 Bar