

Marefa In Line Pump Filler

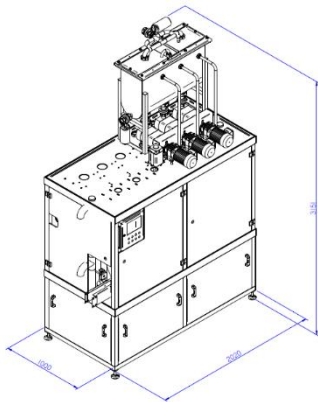

Single Lane Pump Filler

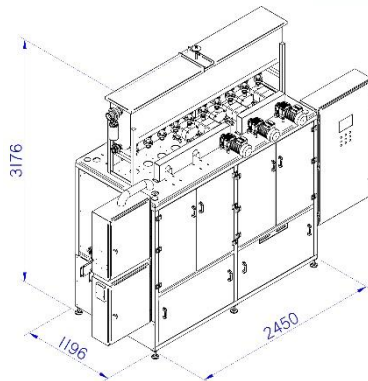

Dual Lane Pump Filler



FEATURES

- Single or dual lane range
- Range consists of lobe & gear pump or piston filling.
- Modular design to allow for additional pumps to accommodate production growth.
- PLC controlled allows for individual pump control and product recipe library, (on lobe and gear pump fillers)
- CIP optional
- Easy adjustment for different containers

NOTE: Filling speeds may vary as they are subject to bottle design and product.

PRODUCTS

- Sauces
- Creams & Gels
- Spreads
- Oils